



ISO 9001 Quality Management System | WBENC-Certified WBE | THE TRAILER EXPERTS - SINCE 1974

Product Sheet

Felling Trailers, Inc. 2021

www.felling.com • 1-800-245-2809

1525 Main Street South

Sauk Centre, MN 56378

| | |
|----------------------------|---------------------|
| FT-14-2 Double Reel | Utility Reel |
|----------------------------|---------------------|

GVWR LBS: 16,100

GAWR LBS: 14,100

WEIGHT LBS: 3,300

CAPACITY LBS: 12,800

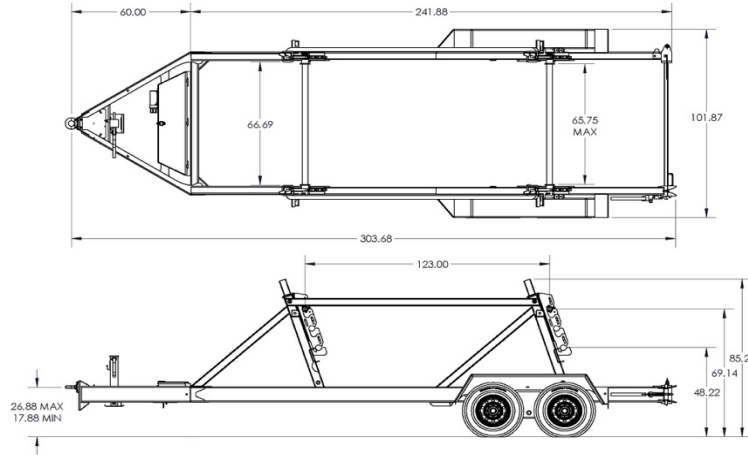

| Feature Name | Standard Features | Std. Qty | UOM |
|---------------------------|---|----------|------|
| Model | FT-14-2 Double Reel | 1 | |
| Reel Capacity | Capacity for Two 65" X 120" Reels, 2.875" shaft with Separate Hydraulics | 1 | Std |
| Reel Capacity | Reel Diameter at lowest position, 66" Reel | 1 | Std |
| Overall Length | Overall Length in Feet | 23 | Feet |
| Width | 102" OD, 66" ID Approx | 1 | Std |
| Brakes | Electric, FSA (Fwd Self Adj) On All Axles | 1 | Std |
| Suspension | Walking Beam Greaseable | 1 | Std |
| Axles | 7K Axle Stubs | 2 | Std |
| Tires & Wheels | ST235/80R 16 E, 8 Bolt [16 x 6] Mod | 4 | Each |
| Hitch Type | 2.5" Adjustable Lunette Eye/Pintle, [C] 42,000 lb Plate Mount (5/8" Bolt) | 1 | Std |
| Jack | 12K Drop Leg, Side Wind | 1 | Std |
| Plug | 7 Pole RV | 1 | Std |
| Lights | LED Lights (Peterson), Sealed Wiring Harness | 1 | Std |
| Trailer Color | Felling Black # CCA945378 (White Felling Decal) | 1 | Std |
| Standard | Elec/Hydraulic Pump with 12 V battery in Lockable Enclosure | 1 | Std |
| Standard | 3/8" Safety Chains, Grade 70 | 1 | Std |
| Standard | Document Holder | 1 | Std |
| GVWR | 16,100 lbs | 1 | Std |